



FEATURES

- Robust, no moving parts for long life
- Custom flow connectors & installation lengths
- Excellent repeatability (± 0.05 % of flow rate)
- Optional Net Oil functionality

BENEFITS

- ▶ Increased productivity, less maintenance
- ▶ Lower installation cost
- ▶ Increased product quality
- ▶ Simpler whole solution for Net Oil without PLC/RTU

FLOW RATE

Mass Flow Rate (max.):	230,000 kg/h [8,450 lb/min]
Volumetric Flow Rate (max.):	230,000 l/h [1,013 gpm, 34,720 oil bbl/d (US)]
Nominal Meter Size:	DN80 [3"]

PRESSURE RATING 100 bar [1,450 psi]

ACCURACY (LIQUIDS)¹⁾

Basic Accuracy (Mass Flow) ²⁾ :	± 0.3 % (option: up to ± 0.15 % of flow rate)
Repeatability (Mass Flow):	± 0.05 % of flow rate
Basic Accuracy (Volume Flow) ²⁾ :	± 0.3 % (option: up to ± 0.2 % of flow rate)
Repeatability (Volume Flow):	± 0.05 % of flow rate
Zero Stability:	± 0.015 % of full scale

ACCURACY (GASES)

Basic Accuracy (Mass Flow) ²⁾ :	± 1 % (option: up to ± 0.5 % of flow rate)
Repeatability (Mass Flow):	± 0.25 % of flow rate

DENSITY

Density Range:	up to 2,500 kg/m ³ [2.5 g/cm ³]
Density Accuracy ²⁾ :	± 1.0 kg/m ³ [± 0.001 g/cm ³]
Density Repeatability:	± 0.5 kg/m ³ [± 0.0005 g/cm ³]

TEMPERATURE

Process Temperature Range:	-40 °C ... +100 °C [-40 °F ... +212 °F] Option: -60 °C ... +200 °C [-76 °F ... +392 °F]
Temperature Accuracy:	± 1 °C ± 0.5 % of reading [± 1.8 °F ± 0.5 % of reading]
Temperature Repeatability:	± 0.2 °C [± 0.36 °F]

MATERIALS (WETTED PARTS)

Tubes:	1.4404 [AISI 316L]
Case:	1.4404 [AISI 316L]
Flow Splitter:	CF3M [1.4409]
Option:	NACE MR 0175/0103 compliant

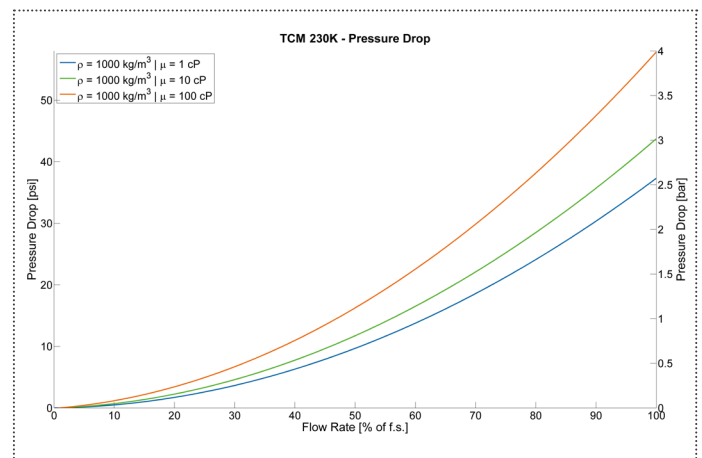

¹⁾ Stated flow accuracy combines the effects of repeatability, linearity and hysteresis.
²⁾ The specifications refer to standard conditions (for further information see TCM CLASSIC series manual).



CLASSIC Series | TCM 230K Coriolis Mass Flow Meter

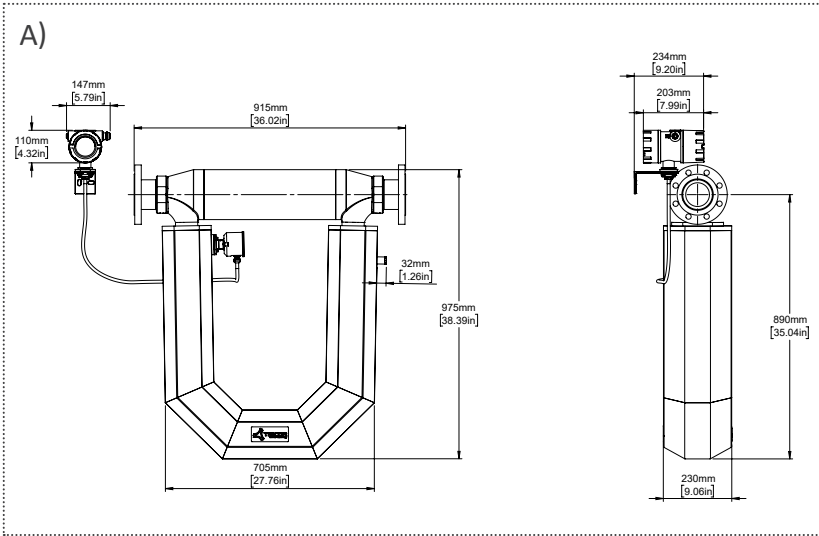

METER DIMENSIONS³⁾ AND WEIGHTS

A) Remote Version

Weight: 87 kg [191.8 lb]

With junction box and remote field mount

Standard Process Connection

DN80 PN40 [3" ANSI CL 300] (others on request)

APPROVALS & CERTIFICATIONS

ATEX Zone 1 IECEX	Compact version: II 2G Ex db ia IIB T4 Gb Remote version⁵⁾: Sensor: II 1G Ex ia IIB T4...T2 Ga Transm.: II 2(1)G Ex db [ia Ga] IIB T4 Gb
Atex Zone 2 cCSAus ⁴⁾	All versions: II 3G Ex nA IIB T4 Compact version: Cl. 1, Div. 1, Group C, D: T4 (US, Can) Ex db ia IIB T4 Gb (Can) Remote version⁵⁾: Sensor: Cl. 1, Div. 1, Group C, D: T4...T2 (US, Can) Ex ia IIB T4...T2 Ga (Can) Transm.: Cl. 1, Div. 1, Group C, D: T4 (US, Can) Ex db [ia Ga] IIB T4 Gb (Can)
EAC (TR-CU)	Compact version: 1Ex d ia IIB T4 Gb X Remote version⁵⁾: Sensor: 0Ex ia IIB T4...T2 Ga X Transm.: 1Ex d [ia Ga] IIB T4 Gb X
KGS (Korean)	Compact version: Ex d [ia] IIB T4 Remote version⁵⁾: Sensor: Ex ia IIB T4 Transm.: Ex d [ia] IIB T4

PANEL MOUNT⁶⁾

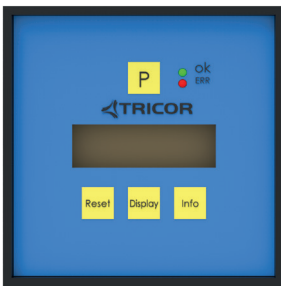

REMOTE MOUNT⁷⁾

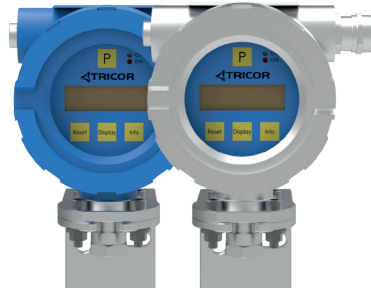

ELECTRONICS

Power Supply: 24 V DC or 100 ... 240 V AC (version dependent)

Outputs: Analog, Frequency, Pulse, Status

Interfaces: RS485 RTU (Modbus), HART[®]

Cable Gland: M20 | ½" NPT

³⁾ Drawing of the Meter Dimensions reflects one standard connection, other connections on request (Installation length can vary depending on selected connection).

⁴⁾ For cCSAus the electronic is only available in aluminum housing.

⁵⁾ Only wall mounting, not panel mounting.

⁶⁾ Weight: 0.4 kg [0.88 lb].

⁷⁾ Weight with aluminum diecast housing: 3.8 kg [8.4 lb] with 3 m cable.

www.tricorflow.com



NORTH & SOUTH AMERICA

AW-Lake Company
2440 W. Corporate Preserve Dr. #600
Oak Creek WI 53154 | USA
+1 414 574 4300

ASIA PACIFIC & MIDDLE EAST

KEM Küppers Elektromechanik GmbH
Liebigstraße 5
85757 Karlsfeld | Germany
+49 8131 59391-0

CHINA

KEM flow technology (Beijing) Co., Ltd.
Rm. 906, Block C, Ruiipu Office Bldg, No. 15
HongJunYingNan Road
Chaoyang District, Beijing 100012 | China
+86 10 84929567

EUROPE (ROW)

KEM Küppers Elektromechanik GmbH
Liebigstraße 5
85757 Karlsfeld | Germany
+49 8131 59391-100